

# ***Twin Belt Transport Unit***



## ***For Bottom Coding Applications***

The Twin Belt Transport Unit is designed for in-line transfer of containers for ease in bottom coding, labeling or inspection between two existing conveyors. The Transport Unit allows smooth transfer between most types of conveying systems. The twin geared 90 Volt DC variable speed synchronized drives ensure that existing conveyor speeds are matched. The Twin Belt Transport Unit can also be used to stabilize containers from unscramblers, labelers, fillers, etc.

### **Applications:**

- Inkjet Printing
- Laser Marking
- Labeling
- Inspection / Verification

### **Features:**

- Mount Between Conveyors
- Stainless Steel Construction
- Floor stand with height adjustment
- 90 Volt DC motors with variable speed
- Optional print head mounts
- Optional label applicator mounts

***CMI***

*Certified Machinery Inc.  
3175 Princeton Pike  
Lawrenceville, NJ 08648  
(609) 912-0300*

[www.certifiedmachinery.com](http://www.certifiedmachinery.com)

# Twin Belt Transport Unit

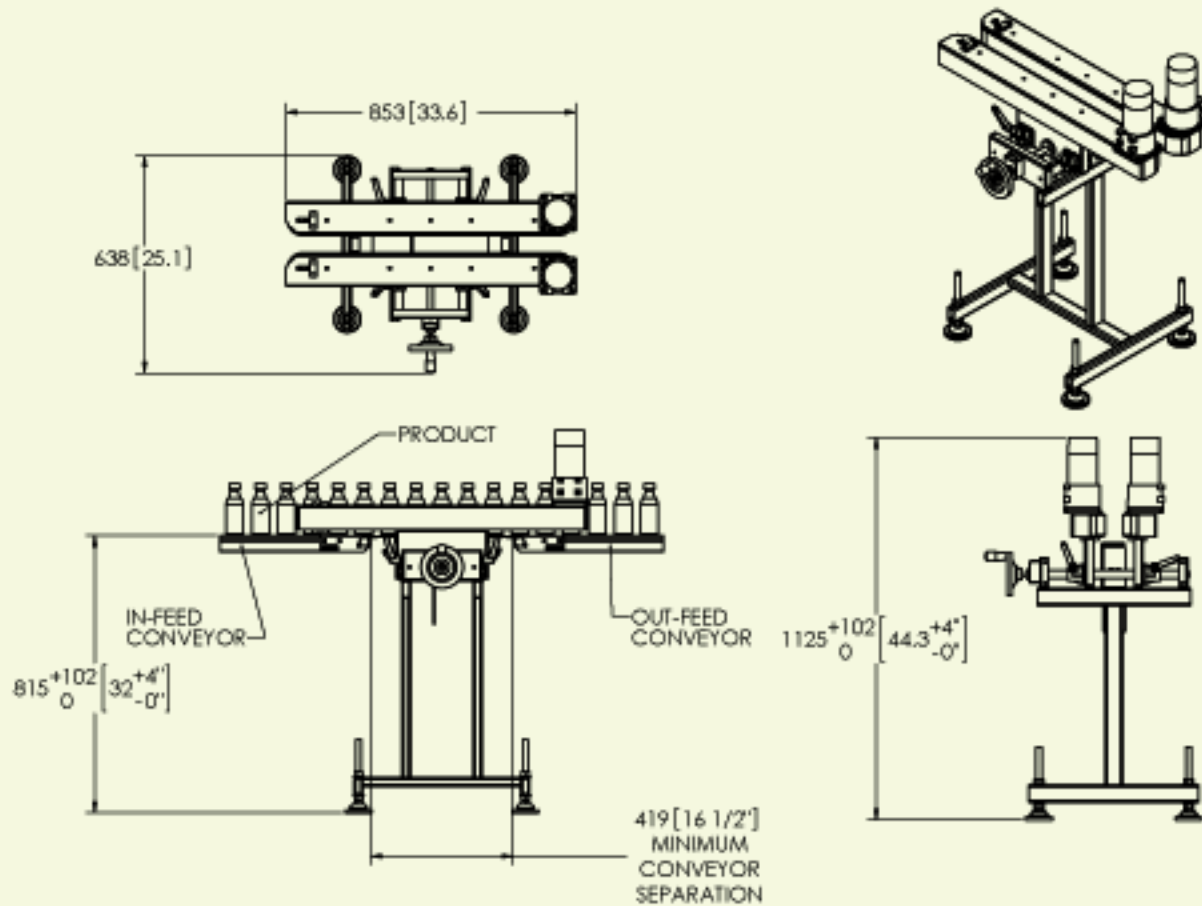

Construction: Stainless Steel with plastic sub components, high-grip drive "V" grooved belts for non-scuffing of product.

Drive: 90 Volt DC motors with variable speed

Power Requirements: 110 Volt supply; 2.0 kW loading

Throughput: Up to 150 feet per minute. High Speed Version Available

Size Range: Containers up to 6 1/2 in

Approximate Dimensions: H 32 - 36 in.: L 33.6 in

**CMI**

Certified Machinery Inc.  
3175 Princeton Pike  
Lawrenceville, NJ 08648  
(609) 912-0300

[www.certifiedmachinery.com](http://www.certifiedmachinery.com)